



# GLACIER SERIES



- Available as cool & cold, or hot & cold
- Accommodates Australian Standard bottles.
- Can adapt to suit a variety of water purifiers
- Lift-out reservoir
- Mains Pressure conversion kit available
- 2 Year Comprehensive Wholesale Warranty

Black option also available



Cool & Cold also available



Optional matching bottle cover available



May be converted to Mains Pressure POU (Kit required)

# GLACIER SERIES

## GENERAL FEATURES

Our GLACIER Series bottle top water coolers provide refreshing Cool & Cold or Hot & Cold water in a cooler designed to make refurbishing and maintenance a breeze. They are able to accommodate all Australian standard spring water bottles and a variety of purification devices, if you prefer to use mains pressure water in a particular application, they also have the added versatility of being converted to a mains pressure, (P.O.U.) unit when combined with the optional conversion kit.

## SPECIFICATIONS:

### CABINET:

Moulded from one piece of UV stabilised, high-density polyethylene (HDPE), the Glacier series cabinet is completely rust proof. The single piece cabinet is designed to allow easy cleaning, sanitisation and refurbishment exchange.

### DRIP TRAY:

Moulded from durable, impact resistant plastic and has sufficient volume to hold the collect the occasional spills that may result from day to day use. The drip tray is removable for periodic cleaning.

### TAPS:

High impact polypropylene lever type. Fast flowing and easy to operate they are also recessed for added protection against accidental activation by passing pedestrian traffic. The Hot tap also features a child resistant mechanism, (fitted to hot & cold models only).

### COOLING RESERVIOR:

Constructed of food grade, high-density polyethylene (HDPE) and approximately 4.7 Litres in capacity. The reservoir features large radius corners to facilitate sanitisation. The integrated waterway and baffle system provides two zones of refrigeration. One supplies the cold water tap and the other, either the cool water tap, (on cool & cold models) or the hot water tank, (on hot & cold models).

### HOT TANK:

Fabricated from Type 304 stainless steel, the hot tank features a 500 Watt sheathed heating element and is accurately controlled with a contact thermostat. Tank capacity is approximately 4.8 litres. (Fitted to hot & cold models only).

## REFRIGERATION SYSTEM:

This static condenser system utilises R134a refrigerant which is non toxic, non-flammable and non ozone depleting. Refrigerant flow is controlled by capillary tube, which has no moving parts and the compressor is protected by an automatic overload, is also lifetime lubricated and hermetically sealed. The tube on tank style evaporator has six (6) coils around the storage tank for balanced, efficient cooling and the entire system is controlled by an adjustable, (factory pre-set) thermostat.

## ELECTRICAL:

240 Volts 50Hz single phase. A 1.8 metre house cable and 3 pin plug is supplied. Full load current is 1.5 amps.

## COOLING PERFORMANCE:

Cold water: Approx 5 litres per hour @ approximately 10°C

Cool water: Unlimited, (subject to continuous supply)

Hot water: Approx 6 litres per hour @ approximately 88°C (hot & cold only)

### \*CRITERIA:

Ratings are based on intermittent use under environmental conditions of ARI Standard 1010 (self contained, mechanically refrigerated drinking water coolers) and UL399 (drinking water coolers).

## WEIGHTS AND DIMENSIONS:

GLACIER	WEIGHT	WIDTH	DEPTH	HEIGHT	SHIPPING VOLUME
NETT	12.7kg	320mm	320mm	990mm	
PACKED	13kg	330mm	330mm	1000mm	0.109M <sup>3</sup>

## WARRANTY:

The entire range of Waterworks Glacier Series water coolers are covered by a 2 Year Comprehensive Wholesale Warranty (copy available on request). The warranty provides comprehensive parts and labour coverage, for the period of 2 years from the date of original sale.

*As part of Waterworks Australia's policy of continuous improvement, we reserve the right to alter specifications at anytime without notice.*

Distributed by...



Waterworks Australia Pty Ltd ABN 51 064 901 239  
48 Neumann Road Capalaba Queensland 4157  
Phone (07) 3390 3777 • Fax (07) 3390 1766  
Email sales@water-works.com.au • www.water-works.com.au



# B5 SERIES



- A very reliable workhorse
- Bottle top water coolers
- Available as Cool & Cold or Hot & Cold
- Lead Free Waterways.
- Floor standing or Counter Top
- Stainless Steel Reservoir
- Cloud white finish
- Wide removable drip tray and grid
- Envable Serviceability
- 2 year Comprehensive Warranty
- Durable UV protected ABS and painted steel cabinet



The Aquanet® drop in filter is designed to fit the B series perfectly.



Includes integral no-spill spike (removable).



Child resistant hot tap, (hot and cold units only).

# B5 SERIES

## GENERAL FEATURES

The Waterworks® B5 Series bottled water dispensers continue to lead the way with advanced technological innovations. Refined yet durable, they have a captivating modern style which harmonises with a variety of decors. They are engineered to the highest levels of quality, dependability and service and are the proven performers in Australia's harsh climatic conditions.

## CONSTRUCTION

**COLD WATER RESERVOIR:** Type 304 stainless steel tank, which provides superior chilling. The highly polished surface is easy to clean and maintain. Easy to replace insulation.

**HOT TANK:** Type 304 stainless steel. 500 Watt sheathed heater installed in the tank ensures accurate temperature control. On/Off switch is easily accessible at side of cabinet. Tank capacity is 2 litres.

**CABINET:** Top and front panels are moulded of UV treated ABS and side panels are zinc coated steel sheets covered in electrostatically applied high polymer polyester resin.

**COLOUR:** High gloss cloud white available as standard.

**TAPS:** Durable polypropylene self-closing design - easy to operate. They are fully recessed for protection and are lever type, with fast flow for ease of operation. Hot tap has safety influence.

**FUNCTION STATUS DISPLAY:** Waterwork's unique design. This exclusive device illuminates a green and red signal indicating the power/hot/cold position of the dispenser.

## OPTIONS

**NO SPLASH VALVE:** Allows the bottle to be changed without excess spillage. Just place the bottle on the cooler and the valve opens to let water through. If you need to remove the bottle, the valve automatically closes. The water flow is more constant and therefore there is less cyclic stress on the bottle for added safety against bottle fractures.

**AQUANET FILTER (AN-1)** The Waterworks AN-1 Aquanet filter is specifically designed to compliment your B5 Series Cooler. Simply remove the patented No-Spill Spike assembly and replace it with an optional Waterworks scuff ring (SR-5) to provide a stable base for your gravity feed filtration system. The No Splash Valve mentioned above is also the ideal accessory for this configuration.

## SPECIFICATIONS

**REFRIGERATION SYSTEM:** CFC-free refrigerant which is non-toxic, non-flammable and non-ozone depleting. Refrigerant flow is controlled by capillary tube which has no moving parts. The compressor is hermetically sealed with automatic overload protection. Lubricant is not needed.

**CONDENSER:** Quiet operating air-cooled static type. No moving parts.

## PERFORMANCE

Tap 1      Outlet water 9°C approx.  
Tap 2      Outlet water 18°C approx.  
Hot Tap    Outlet water 92°C approx.

## CAPACITIES:

ROOM TEMP °C	21	27	32
150ML CUPS/HR 10°C	44	32	18
LITRES/HR AT 10°C	4.2	3.1	1.8

**HOT WATER DELIVERY:** 45 x 170ml cups per hour

*\*Intermittent use only, continuous use will result in reduced performance.*

**ELECTRICAL:** 220 Volts 50Hz single phase. A 1.5 metre house cable and 3 pin plug is supplied. Full load current is 1.2 amps.

## SHIPPING WEIGHTS & DIMENSIONS:

MODEL	WEIGHT	MODEL	WEIGHT	WIDTH	DEPTH	HEIGHT
B5C	19kg	BB5CH	21kg	310mm	310mm	950mm
SB5C	14kg	SB5CH	16kg	310mm	310mm	534mm

**QUALITY:** The specifications of these coolers are manufactured to comply with the standards of underwriters laboratories.

## WARRANTY:

The entire range of Waterworks B5 Series water coolers are covered by our 2 Year Comprehensive Warranty (copy available on request). The warranty provides comprehensive parts and labour coverage, for the period of 2 years from the date of original sale.

*As part of Waterworks Australia's policy of continuous improvement, we reserve the right to alter specifications at anytime without notice.*

Distributed by...



Waterworks Australia Pty Ltd ABN 51 064 901 239  
48 Neumann Road Capalaba Queensland 4157  
Phone (07) 3390 3777 • Fax (07) 3390 1766  
Email sales@water-works.com.au • www.water-works.com.au



# B10 SERIES



- New Elegant Design
- Lead Free Waterways
- Stainless Steel Reservoir
- Wide Removable Drip Tray
- Two Year Comprehensive Warranty
- Available in Cool & Cold or Hot & Cold
- Convert-a-Cooler (Point of Use conversion kit available)



Cool & Cold  
(B10C) also available



Concealed  
(yet accessible) controls



Includes integral  
no-spill spike (removable)

# B10 SERIES

## GENERAL FEATURES

### CABINET

Combining stylish design and durability, the "cloud white" cabinets are a combination of high impact ABS plastics and powder painted steel. All surfaces are easy to clean and provide superior resistance to UV light.

### FAUCETS

Made from durable polypropylene, these self-closing faucets are hygienic and easy to operate. The B10CH (Hot & Cold unit) also features a child resistant hot tap and all faucets on the B10 Series coolers come with the added reassurance of NSF18 approval.

### DRIP TRAY

The removable drip tray is durable and dishwasher safe.

### COLD WATER RESERVOIR

Constructed of hygienic 304 stainless steel the tank holds 2.3 litres of water.

### COLD THERMOSTAT

Temperature is accurately controlled from 5-10 degrees Celsius with an adjustable thermostat, accessible at the side of the cabinet.

### REFRIGERATION UNIT

The system utilises almost silent, convection cooled (static) condenser, with an externally wound evaporator coil and hermetically sealed compressor.

### HOT WATER TANK

Manufactured from 304 stainless steel and containing a highly efficient internal heating element, the hot tank is activated with the isolating switch within the control box. (B10CH only).

### HOT WATER THERMOSTAT

Hot water temperature is controlled to approximately 90 degrees Celsius with an automatic thermostat.

## ELECTRICAL

B10 units come complete with a 2 Metre power cord suitable for any 220V 50Hz 1Ph general power outlet.

## POWER STATUS DISPLAY

Located on the front of the B10 series coolers, these LED indicators will show when power is being supplied to each of the coolers systems

## WARRANTY

The B10 Series of bottle top water coolers are covered by the Waterworks 2 Year Comprehensive Warranty, providing protection for both parts and labour for a period of 2 years.

## CONTAINER LOADING QUANTITY

20' container: 270 units 40': container: 558 units.

## QUALITY

As with all Waterworks products, the B10 series of bottle top water coolers are manufactured to the highest quality standards. Their reliability and innovation, make them the leaders in the Australian and New Zealand water treatment industries.

## SPECIFICATIONS

MODELS	B10CH	B10C
COLD WATER (approx 10°C)	5.5LPH	5.5LPH
HOT WATER (approx 85°C)	7.5LPH	N/A
ROOM TEMP. WATER	N/A	UNLIMITED
DIMENSIONS	310mm WIDE x 310mm DEEP x 950mm HIGH	(without the bottle)
SHIPPING WEIGHT	21KG	19KG

*Cold and hot water: the above rates tested in ambient temperature 32°C, water inlet temperature 27°C*

*As part of Waterworks Australia's policy of continuous improvement, we reserve the right to alter specifications at anytime without notice.*

*Distributed by...*



Waterworks Australia Pty Ltd ABN 51 064 901 239  
48 Neumann Road Capalaba Queensland 4157  
Phone (07) 3390 3777 • Fax (07) 3390 1766  
Email sales@water-works.com.au • www.water-works.com.au



# B19/SB19 SERIES

## THE NEXT GENERATION!



- Stylish high gloss black and stainless look cabinet
- Available in hot/cold or cool/cold
- Accommodates the Waterworks® Aquanet® or Self fill bottle
- Large 3.3L stainless steel cold tank
- Sleek easy push taps
- Hot water safety tap
- Access plate on side of SB19C
- 2 year comprehensive warranty

# B19/SB19 SERIES

## THE NEXT GENERATION!

### GENERAL FEATURES

The Waterworks® 19 Series is the latest in a series of water coolers renowned for reliability, longevity and value for money. The classy cabinet will complement the most stylish office or enhance any home décor.

### PERFORMANCE

Tap 1 Outlet water 9°C approx.  
 Tap 2 Outlet water 18°C approx.  
 Hot Tap Outlet water 85°C approx.

### CAPACITIES:

ROOM TEMP °C	21	27	32
150ML CUPS/HR 10°C	44	32	18
LITRES/HR AT 10°C	4.2	3.1	1.8
HOT WATER DELIVERY: 45 x 170ml cups per hour			

*\*Intermittent use only, continuous use will result in reduced performance.*

**ELECTRICAL:** 220 Volts 50Hz single phase. A 1.5 metre house cable and 3 pin plug is supplied. Full load current is 1.2 amps.

### SHIPPING WEIGHTS & DIMENSIONS:

MODEL	NET WEIGHT	SHIPPING WEIGHT	NET WIDTH	NET DEPTH	NET HEIGHT	SHIPPING WIDTH	SHIPPING DEPTH	SHIPPING HEIGHT
B19C	15.5kg	17.5kg	272mm	313mm	965mm	285mm	340mm	995mm
B19CH	16kg	18kg	272mm	313mm	965mm	285mm	340mm	995mm
SB19C	13kg	15.4kg	272mm	420mm	448mm	285mm	502mm	516mm
SB19CH	14kg	16kg	272mm	420mm	448mm	285mm	502mm	516mm

### SPECIFICATIONS

**Cabinet:** High gloss cabinet. Front and top ABS plastic. Side panels are high polymer coated steel / pre coated metal.

Bench top model has removable side panels for internal access.

**Colour:** Black/Silver

**Faucets:** Soft closing and easy to operate. Child resistant hot taps on hot / cold models.

**Drip Tray:** Durable ABS plastic, easy clean.

### HOT WATER:

**Tank:** Stainless steel. Efficient internal heating element. Non-adjustable thermostat with manual reset safety limiter. Convenient hot water on/off switch.

### COLD WATER:

**Cooling reservoir:** Hygienic stainless steel 3.3L chilling tank with contaminant seal. Adjustable thermostat with easy access from the back of the unit.

### REFRIGERATION:

Convection cooled condenser. Hermetically sealed compressor with automatic overload protector. Refrigerant type R134A

### ELECTRICAL:

240 volt 50HZ single phase. 1.5 metre cable and 3 pin plug is supplied.

### WARRANTY:

The entire range of Waterworks 19 Series water coolers are covered by our 2 Year Comprehensive Warranty (copy available on request). The warranty provides comprehensive parts and labour coverage, for the period of 2 years from the date of original sale.

*As part of Waterworks Australia's policy of continuous improvement, we reserve the right to alter specifications at anytime without notice.*

Distributed by...





Get the *inside story* from  
*Waterworks!!*

*Not everything is as it seems.  
Looks like a POU cooler but...*

*...our new "STORM" bottled  
water cooler offers  
fresh and exciting features  
from top to bottom.*



*To get the full inside story call  
Waterworks Australia on  
07 3390 3777*

*Tamper resistant top  
ensures the reservoir  
is secure.*

*Concealed faucets with  
replaceable water contact  
components to protect  
from contamination.*

*The "Smartflo" water  
reservoir and waterline  
can be completely  
removed within seconds  
for thorough cleaning  
and sanitising.*

*Removable drip tray  
for easy cleaning.*

*The bottom load dispenser  
means no more heavy  
lifting. Just open the front  
sliding panel and place  
the bottle into the  
base of the cooler.*

*The concealed bottle  
cavity greatly reduces  
the possibility of mould  
and algae build-up in  
bottles. Perfect for  
sunny office areas  
where complaints of  
green bottles are common.*





# AVALANCHE

## BENCH TOP BOTTLED WATER COOLER



- Designed to fit conveniently on a kitchen or office bench
- "Evaporator Band" cooling technology
- Carrying handle makes dispenser easy to carry
- LED display indicates when cold and hot water are at optimum temperature
- Small footprint
- Compressor operated
- One piece dish washer safe drip tray
- Hot/cold & cool cold options available
- Easily converts to POU mains connected cooler (optional)



Filter bottle fits cool/  
cold and hot/cold models



Matching cup dispenser  
available

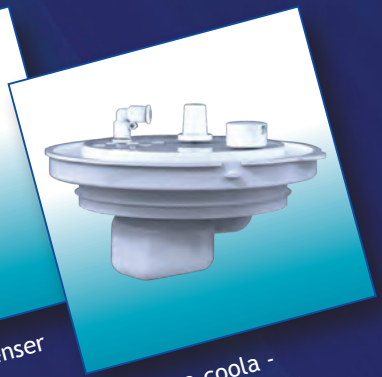

Convert-a-coola -  
easily converts to a  
Point of Use system

# AVALANCHE

## BENCH TOP BOTTLED WATER COOLER

### GENERAL FEATURES

The Avalanche is a water dispenser designed to fit conveniently on a kitchen or office counter. This unique design offers effective cooling through the proven "evaporator band" cooling technology.

**Great performance from a small dispenser!**

#### Cabinet:

Blow molded, high density polyethylene (HDPE) together with injection molded bottom plate.

#### Faucets:

Constructed of FDA approved nylon and silicon tubing. Child proof hot water faucet.

#### Drip tray:

The removable drip tray is durable and dishwasher safe.

#### Cold water thermostat:

Preset at factory to dispense water at temperatures between 6 -10°C

#### Hot water thermostats and heater:

Automatic thermostat set at temperature range of 75-87°C

Manual thermostat reset in case of automatic thermostat failure.

420W internal heater

On/off switch for hot tank is located at the back of the cabinet.

#### Compressor:

Hermetically sealed reciprocating compressor (220-240VAC/60Hz (100-115VAC/60Hz)

#### Refrigerant type:

R134A (CFC Free)

#### Weight:

Hot/Cold: 12.9kg

Cool/Cold: 12.3kg

#### Dimensions:

D 369mm X W 330mm X H 419mm

#### Shipping:

D 375mm X W 360mm x H 447mm



*Convert-a-Coola  
(Bottle top conversion  
kit available)*



*Alternative colour  
options available*

As part of Waterworks Australia's policy of continuous improvement, we reserve the right to alter specifications at anytime without notice.

*Distributed by...*



Waterworks Australia Pty Ltd ABN 51 064 901 239  
48 Neumann Road Capalaba Queensland 4157  
Phone (07) 3390 3777 • Fax (07) 3390 1766  
Email sales@water-works.com.au • www.water-works.com.au



# AQUANET<sup>®</sup>

GRAVITY FEED WATER FILTRATION



- Water on tap and filtered at the point of use
- Great tasting healthy drinking water
- Guaranteed quality of water
- No plumbing required
- Lateral flow distribution to prevent channelling.
- Filter base perforations for saturated water distribution.
- Integral guide rails centrally locate and align bottle neck.
- Optional reusable non-spill cap automatically releases water when needed. No spill. No mess.



Non Spill Valve



Aquanet Filter



Easy Installation

# AQUANET® GRAVITY FEED WATER FILTRATION

## FEATURES & BENEFITS

The Aquanet® filter adds a refreshing new dimension to bottled water centres. It offers advanced design and user-friendly features resulting in great tasting, healthy drinking water.

### FUNCTION

The Aquanet® functions through a combination of adsorption, absorption, ion exchange and mechanical filtration. Aquanet® filters the water as it leaves the bottle and reduces water borne contaminants before it reaches the reservoir.

The four stage filter media substantially reduces chlorine, bad taste, odour and colour, along with organic impurities, pesticides, herbicides, detergent, dirt, rust and heavy metals such as lead, mercury and aluminium.

### INSTALLATION

Aquanet™ installs in seconds. It fits perfectly into the cooler or crock. There are no bolts or screws. No tools required.



*As part of Waterworks Australia's policy of continuous improvement, we reserve the right to alter specifications at anytime without notice.*

## TECHNICAL DATA

- Stage 1: 5 micron needle felt membrane pre-filter.
- Stage 2\*: 5 micron weak acid cation resin for reducing hardness, heavy metal and chlorine.
- Stage 3\*\*: High grade activated carbon for reducing chlorine, compounds, taste, rust & odour.
- Stage 4: 5 micron needle felt membrane final filter.

\*Weak acid cation resin is designed to reduce alkalinity and hardness in water. It is also excellent for the reduction of heavy metals and chlorine.

\*\*EPA approved silver carbon is designed for reducing organic chemicals such as TCE, THM and EDB, plus reducing chlorine. The addition of silver inhibits the growth of bacteria.

## OPTIONS

Bottle: 15L P.E.T. Bottle

No Spill Valve: Allows the bottle to be changed without spillage. The valve automatically opens and closes to release water only when required. (Fits most 8, 11, 15 & 19 litre bottles).

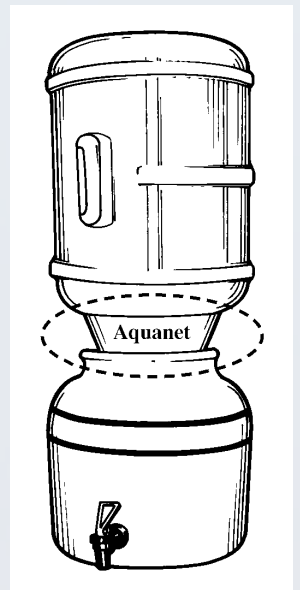
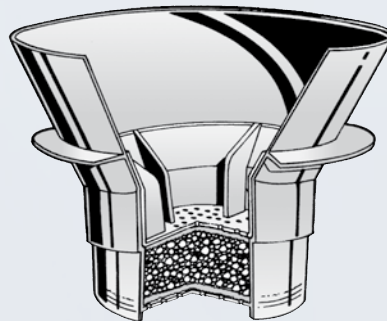

*Distributed by...*



Waterworks Australia Pty Ltd ABN 51 064 901 239  
48 Neumann Road Capalaba Queensland 4157  
Phone (07) 3390 3777 • Fax (07) 3390 1766  
Email sales@water-works.com.au • www.water-works.com.au



# SFB-3 SELF FILL BOTTLE



- An economical filter option for homes & offices
- Great tasting filtered water at a fixed price
- Greatly reduces bad taste and odour due to chemical additives in tap water
- Produces up to 8L per hour
- Fits all Waterworks bottle top water coolers and ceramic dispensers
- Easily installed
- No heavy lifting - reduces OH&S risks.



F-RB3 Replacement cartridge



Ceramic well



Bottled water cooler

# SFB-3 SELF FILL BOTTLE

## GENERAL FEATURES

### ACCESSIBILITY:

Waterworks Self-Fill Bottle is the perfect partner for all bottled water coolers or ceramic dispensers.

### MEDIA:

3 Stage filtrations

- Resin
- Activated carbon
- Ceramic disc
- Filters are certified for 4000 litres, which equates to approximately 6 months use.
- Filter cartridges should be replaced 6 monthly

### APPLICATION:

- Water filter cartridge (For use with potable water only)
- Greatly reduces bad taste and odour in town supply water.

Operating temperature 5C - 38C

### MODEL F-RB3C

MEDIA	3 stage - Resin, activated carbon, ceramic disc. Water Filter Cartridge (Potable water)
APPLICATION TEMPERATURE LIMIT	38 degrees Celsius

### SHIPPING WEIGHTS & DIMENSIONS:

LENGTH	WIDTH	DEPTH	SHIPPING WEIGHT	UNIT WEIGHT
304mm	302mm	301mm	4.3kg	3.3kg



*As part of Waterworks Australia's policy of continuous improvement, we reserve the right to alter specifications at anytime without notice.*

*Distributed by...*



Waterworks Australia Pty Ltd ABN 51 064 901 239  
48 Neumann Road Capalaba Queensland 4157  
Phone (07) 3390 3777 • Fax (07) 3390 1766  
Email sales@water-works.com.au • www.water-works.com.au



B-Glacier bottled water cooler



# Converta Coola



D-Glacier Mafns pressure drain free water cooler



OR



[www.water-works.com.au](http://www.water-works.com.au)

07 3390 3777

One cooler for both applications "Bottled or Filtered"



**Our Conversion Kits take minutes to install and can be done on location**



**B10**



**D10**



**B7**



**D7**



**WHITE GLAC B**



**WHITE GLAC D**



**BLACK GLAC B**



**BLACK GLAC D**



**SUMMIT B**



**SUMMIT D**



**B14**



**D14**



**AVALANCHE B**



**AVALANCHE D**



**ALPINE B**



**ALPINE D**



**B GLACIER  
with bottle cover**



**D GLACIER  
with filter base**

*Distributed by:*



Waterworks Australia Pty Ltd ABN 51 064 901 239  
 48 Neumann Road Capalaba Queensland 4157  
 Phone (07) 3390 3777 • Fax (07) 3390 1766  
 Email sales@water-works.com.au • www.water-works.com.au



# D5 SERIES

AUSTRALIA'S FAVOURITE P.O.U. WATER COOLERS



- The most reliable POU cooler on the market
- Available in bench-top or floor standing
- Attaches directly to your water source
- Accommodates a variety of water purifiers
- Large integral reservoir (12 litres)
- Easily cleaned and sanitised
- Available as cool & cold, or hot & cold
- 2 Year Comprehensive Warranty



Cup dispenser sold separately



12 Litre removable reservoir



Accessory - Waterworks PG series single or twin filtration system

# D5 SERIES

AUSTRALIA'S FAVOURITE P.O.U. WATER COOLERS

## GENERAL FEATURES

Our D5 series point of use (P.O.U.) Water centres provide a never ending supply of refreshing Hot & Cold or Cool & Cold water. They attach directly to your water source and are able to accommodate a variety of purification devices. The large 12 litre reservoir makes it the ideal choice for use with Reverse Osmosis purification systems and the fast flow levers and high clearance recessed alcove make it easy to draw water.

## SPECIFICATIONS:

### CABINET:

Top and front panels are moulded of UV treated ABS and side panels are zinc coated steel sheets covered in electrostatically applied high polymer polyester resin.

### COLOUR:

High gloss cloud white available as standard.

### DRIP TRAY:

Concealed lift-out design of a high impact durable plastic. Removable for sanitation, it incorporates an anti-splash grid which diverts drain water into the drip tray.

### TAPS:

High impact polypropylene lever type. Fast flow and easy to operate. They're assembled directly onto the reservoir and are fully recessed for added protection. Taps are 177mm above the drain grid allowing ample room for filling kettles and other tall objects. Hot tap has safety influence.

### TOP:

One piece heat resistant plastic. This rust-proof top provides a flat surface to hold small coffee servers and trays.

### FUNCTION STATUS DISPLAY:

Waterworks unique design. This exclusive device illuminates a red green signal indicating the Power/Hot/Cold position of the dispenser.

### COOLING RESERVIOR:

Constructed of polypropylene plastic, approximately 12 litres in capacity. The reservoir features large radius corners to facilitate cleaning. The integrated zoned waterway and baffle system prevents ice rings from restricting chilled water flow. Cold water capacity below the baffle is 4.2 litres. Water above the baffle stays at or about room temperature.

### HOT TANK:

Type 304 stainless steel. 500 Watt sheathed heater installed in the tank ensures accurate temperature control. On/Off switch is easily accessible at side of cabinet. Tank capacity is 2 litres.

### AIR FILTER:

Located on the float assembly for easy access. The air filter contains a replaceable filter disc with a one micron membrane media.

### FLOAT ASSEMBLY:

One stage polyethylene float valve system incorporates a primary float valve which maintains the water level in the reservoir and shuts off when full. The system is designed to operate on an incoming water pressure range of 140-700kPa and a pressure limiting valve should be fitted in situations where the mains pressure may fluctuate to greater than 700kpa.

### REFRIGERATION SYSTEM:

Ozone friendly HFC-134a refrigerant. Flow is controlled by capillary tube which has no moving parts. Condenser is air cooled static type for silent running. No fan assembly is required. Compressor is hermetically sealed, permanently lubricated and protected against motor overload.

### ELECTRICAL:

240 Volts 50Hz single phase. A 1.5 metre house cable and 3 pin plug is supplied. Full load current is 1.5 amps.

## PERFORMANCE:

Tap 1 Outlet water 9DC approx  
Tap 2 Outlet water 18DC approx  
Hot Tap Outlet water 88DC approx

## CAPACITIES CHART

Room Temp	150ml Cups/Hr at 10°C	Litres/Hr at 10°C
21°C	44	6.6
27°C	32	4.8
32°C	18	2.7

### HOT WATER DELIVERY:

45 x 170ml cups p/hr

## SHIPPING WEIGHT:

D5C: 20kg                      SD5C: 15kgs  
D5CH: 22kg                    SD5CH: 17kg

### DIMENSIONS:

D5C/D5CH: 310mmW x 310mmD x 1040mmH  
SD5C/SD5CH: 310mmW x 310mmD x 630mmH

## WARRANTY:

The entire range of Waterworks D5 Series water coolers are covered by a 2 Year Comprehensive Warranty (copy available on request). The warranty provides comprehensive parts and labour coverage, for the period of 2 years from the date of original sale.

*As part of Waterworks Australia's policy of continuous improvement, we reserve the right to alter specifications at anytime without notice.*

Distributed by...



Waterworks Australia ABN 91 902 793 936  
48 Neumann Rd, Capalaba Qld 4157  
Phone 07 3390 3777 • Fax 07 3390 1766  
Email sales@water-works.com.au • www.water-works.com.au



# D10 SERIES

NEW DESIGN - SAME RELIABILITY



- New Elegant Design
- Lead Free Waterways
- Stainless Steel Reservoir
- Wide Removable Drip Tray
- Two Year Comprehensive Warranty
- Available in Cool & Cold or Hot & Cold
- Convert-a-cooler - bottled water conversion kit available



Bottle top version also available



Accessory - swing & twist filtration system



Accessory - matching two piece cup dispenser



# D10 SERIES

## NEW DESIGN - SAME RELIABILITY

### GENERAL FEATURES

#### CABINET

Combining stylish design and durability, the "cloud white" cabinets are a combination of high impact ABS plastics and powder painted steel. All surfaces are easy to clean and provide superior resistance to UV light.

#### FAUCETS

Made from durable polypropylene, these self-closing faucets are hygienic and easy to operate. The D10CH (Hot & Cold unit) also features a child resistant hot tap and all faucets on the D10 Series coolers come with the added reassurance of NSF18 approval.

#### DRIP TRAY

The removable drip tray is durable and dishwasher safe.

#### COLD WATER RESERVOIR

Constructed of hygienic 304 stainless steel the tank holds 2.3 litres of water.

#### COLD THERMOSTAT

Temperature is accurately controlled from 5-10 degrees Celsius with an adjustable thermostat, accessible at the side of the cabinet.

#### REFRIGERATION UNIT

The system utilises almost silent, convection cooled (static) condenser, with an externally wound evaporator coil and hermetically sealed compressor.

#### HOT WATER TANK

Manufactured from 304 stainless steel and containing a highly efficient internal heating element, the hot tank is activated with the isolating switch within the control box. (D10CH only).

#### HOT WATER THERMOSTAT

Hot water temperature is controlled to approximately 90 degrees Celsius with an automatic thermostat.

### ELECTRICAL

D10 units come complete with a 2 Metre power cord suitable for any 220V 50Hz 1Ph general power outlet.

### POWER STATUS DISPLAY

Located on the front of the D10 series coolers, these LED indicators will show when power is being supplied to each of the coolers systems

### WARRANTY

The D10 Series of bottle top water coolers are covered by the Waterworks 2 Year Comprehensive Warranty, providing protection for both parts and labour for a period of 2 years.

### CONTAINER LOADING QUANTITY

20' container: 270 units 40': container: 558 units.

### QUALITY

As with all Waterworks products, the D10 series water coolers are manufactured to the highest quality standards. Their reliability and innovation, make them the leaders in the Australian and New Zealand water treatment industries.

### SPECIFICATIONS

MODELS	D10CH	D10C
COLD WATER (approx 10°C)	5.5LPH	5.5LPH
HOT WATER (approx 85°C)	7.5LPH	N/A
ROOM TEMP. WATER	N/A	UNLIMITED
DIMENSIONS	310mm WIDE x 310mm DEEP x 950mm HIGH	(without the bottle)
SHIPPING WEIGHT	21KG	19KG

*Cold and hot water: the above rates tested in ambient temperature 32°C, water inlet temperature 27°C*

*As part of Waterworks Australia's policy of continuous improvement, we reserve the right to alter specifications at anytime without notice.*

Distributed by...



Waterworks Australia ABN 91 902 793 936  
48 Neumann Rd, Capalaba Qld 4157  
Phone 07 3390 3777 • Fax 07 3390 1766  
Email sales@water-works.com.au • www.water-works.com.au



# D19/SD19

## THE NEXT GENERATION!



- Stylish high gloss black and stainless look cabinet
- Available in hot/cold or cool/cold
- Room for internal filter installation
- Large 3.3L stainless steel cold tank
- Sleek easy push taps
- Hot water safety tap
- Access plate on side of SD19C
- 2 year comprehensive warranty



# D19/SD19

## THE NEXT GENERATION!

### GENERAL FEATURES

The Waterworks® 19 Series is the latest in a series of water coolers renowned for reliability, longevity and value for money. The classy cabinet will complement the most stylish office or enhance any home décor.

### PERFORMANCE

Tap 1 Outlet water 9°C approx.  
 Tap 2 Outlet water 18°C approx.  
 Hot Tap Outlet water 85°C approx.

### CAPACITIES:

ROOM TEMP °C	21	27	32
150ML CUPS/HR 10°C	44	32	18
LITRES/HR AT 10°C	4.2	3.1	1.8
HOT WATER DELIVERY: 45 x 170ml cups per hour			

*\*Intermittent use only, continuous use will result in reduced performance.*

**ELECTRICAL:** 220 Volts 50Hz single phase. A 1.5 metre house cable and 3 pin plug is supplied. Full load current is 1.2 amps.

### SHIPPING WEIGHTS & DIMENSIONS:

MODEL	NET WEIGHT	SHIPPING WEIGHT	NET WIDTH	NET DEPTH	NET HEIGHT	SHIPPING WIDTH	SHIPPING DEPTH	SHIPPING HEIGHT
D19C	15.5kg	17.5kg	272mm	313mm	945mm	285mm	340mm	980mm
D19CH	16kg	18kg	272mm	313mm	945mm	285mm	340mm	980mm
SD19C	13kg	15.4kg	272mm	420mm	438mm	285mm	502mm	516mm
SD19CH	14kg	16kg	272mm	420mm	438mm	285mm	502mm	516mm

### SPECIFICATIONS

**Cabinet:** High gloss cabinet. Front and top ABS plastic. Side panels are high polymer coated steel / pre coated metal.

Bench top model has removable side panels for internal access.

**Colour:** Black/Silver

**Faucets:** Soft closing and easy to operate. Child resistant hot taps on hot / cold models.

**Drip Tray:** Durable ABS plastic, easy clean.

### HOT WATER:

**Tank:** Stainless steel. Efficient internal heating element. Non-adjustable thermostat with manual reset safety limiter. Convenient hot water on/off switch.

### COLD WATER:

**Cooling reservoir:** Hygienic stainless steel 3.3L chilling tank with contaminant seal. Adjustable thermostat with easy access from the back of the unit.

### REFRIGERATION:

Convection cooled condenser. Hermetically sealed compressor with automatic overload protector. Refrigerant type R134A

### ELECTRICAL:

240 volt 50HZ single phase. 1.5 metre cable and 3 pin plug is supplied.

### WARRANTY:

The entire range of Waterworks 19 Series water coolers are covered by our 2 Year Comprehensive Warranty (copy available on request). The warranty provides comprehensive parts and labour coverage, for the period of 2 years from the date of original sale.

*As part of Waterworks Australia's policy of continuous improvement, we reserve the right to alter specifications at anytime without notice.*

Distributed by...



Waterworks Australia ABN 91 902 793 936  
 48 Neumann Rd, Capalaba Qld 4157  
 Phone 07 3390 3777 • Fax 07 3390 1766  
 Email sales@water-works.com.au • www.water-works.com.au



# AVALANCHE

BENCH TOP POU MAINS CONNECTED WATER COOLER  
GREAT PERFORMANCE IN A SMALL PACKAGE!



- Small footprint fits conveniently on kitchen bench or office counter
- LED display indicates when hot & cold water are at optimum temperature
- Compressor driven for efficient water temperature recovery
- 1.8L cold reservoir & 1.4L hot tank
- One piece drip tray is dishwasher safe
- Converta-Coola (Bottle top conversion kits available)
- Double float design
- Excellent chilling capacity



Convert-a-Coola  
bottle top version  
available



Filtration option:  
Premium filters



Installation kits (optional)



# AVALANCHE

## BENCH TOP POU MAINS CONNECTED WATER COOLER

### GENERAL FEATURES

The Avalanche is a water dispenser designed to fit conveniently on a kitchen or office counter. This unique design offers effective cooling through the proven "evaporator band" cooling technology.

**Great performance from a small dispenser!**

#### Cabinet:

Blow molded, high density polyethylene (HDPE) together with injection molded bottom plate.

#### Faucets:

Constructed of FDA approved nylon and silicon tubing. Child proof hot water faucet.

#### Drip tray:

The removable drip tray is durable and dishwasher safe.

#### Cold water thermostat:

Preset at factory to dispense water at temperatures between 6 -10°C

#### Hot water thermostats and heater:

Automatic thermostat set at temperature range of 75-87°C

Manual thermostat reset in case of automatic thermostat failure.

420W internal heater

On/off switch for hot tank is located at the back of the cabinet.

#### Compressor:

Hermetically sealed reciprocating compressor (220-240VAC/60Hz (100-115VAC/60Hz)

#### Refrigerant type:

R134A (CFC Free)

#### Weight:

Hot/Cold: 12.9kg

Cool/Cold: 12.3kg

#### Dimensions:

D 369mm X W 330mm X H 419mm

#### Shipping:

D 375mm X W 360mm x H 447mm



*Convert-a-Coola  
(Bottle top conversion  
kit available)*



*Alternative colour  
options available*

As part of Waterworks Australia's policy of continuous improvement, we reserve the right to alter specifications at anytime without notice.

*Distributed by...*



Waterworks Australia Pty Ltd ABN 51 064 901 239  
48 Neumann Road Capalaba Queensland 4157  
Phone (07) 3390 3777 • Fax (07) 3390 1766  
Email sales@water-works.com.au • www.water-works.com.au



# IC8

REMOTE/UNDERSINK CHILLER



- Lead and copper free waterways
- 1.9 litre stainless steel chilling tank
- 6 Litres/hour cooling capacity
- Stainless steel internal waterways
- Galvalume corrosion resistant cabinet
- 8 cup initial drawoff volume
- Dual, fan assisted static condensers
- Easy to install
- 2 year comprehensive warranty



Connect to virtually any faucet



Ideal for under-sink installations



Pressure relief valve kit included



# IC8

## REMOTE/UNDERSINK CHILLER

### GENERAL FEATURES

The Waterworks IC8 compact, remote chiller is designed for use with drinking fountains, filters, bubblers or glass fillers, thereby enabling any drinking station to supply chilled refreshing water. It can be installed under a sink or bench, in the ceiling, on a column, an adjacent wall, or in a service area. In fact it's perfect for virtually any single remote outlet at home or in the office and with the addition of optional filtration, it delivers fresh, clean, chilled water at the touch of a button.

### SPECIFICATIONS

#### CABINET:

The IC8 cabinet is constructed of "Galvalume," a material with the ideal blend of Aluminium Zinc and Silicone which provides the IC8 with superior heat and corrosion resistance.

#### CHILLING & STORAGE TANK:

Constructed of stainless steel, it has a volume of 1.9 Litres, is fully insulated and independently tested to withstand over 800psi of static pressure. A drain plug and seal is provided, which is removable for servicing. The internal waterlines are 1/4"OD stainless steel and are heliarc welded to eliminate corrosion.

#### REFRIGERATION SYSTEM:

This fan assisted, static condenser system utilises R134a refrigerant which is non toxic, non-flammable and non ozone depleting. Refrigerant flow is controlled by capillary tube, which has no moving parts. The compressor is protected by an automatic overload, is lifetime lubricated and hermetically sealed. The tube on tank style evaporator has six (6) windings around the storage tank for balanced, efficient cooling and the entire system is controlled by an adjustable, (factory pre-set), thermostat.



*As part of Waterworks Australia's policy of continuous improvement, we reserve the right to alter specifications at anytime without notice.*

Distributed by...

### INSTALLATION:

#### GENERAL:

The Waterworks IC8 is ideally suited to installation within a relatively confined space such as under the kitchen sink. As a refrigeration appliance however, it relies upon air exchange to function properly and therefore must be provided with adequate ventilation.

#### PLUMBING CONNECTIONS:

Both the inlet and outlet are recessed, 1/4" stainless steel pipes, suitable for connection to industry standard 1/4" quick connect fittings.

#### ELECTRICAL CONNECTIONS:

The Waterworks IC8 is Furnished with 1.8 metre GPO power cable and plug. 240volts, 50Hz. Single phase. Running amps - 0.74A. Power consumption - 120W (Cooling Capacity).

### COOLING PERFORMANCE:

The Waterworks IC8 is capable of cooling approximately 6\*LPH (litres per hour) at 10°C.

Cooling Speed: From 27°C to 10°C, 21.6 minutes

Cooling Capacity: 5.8 litres/hour/10°C ± 2°C

Draw Off Capacity: 8 cups below 10°C

#### \*Example of Water Temperature of 150ml cups

1st	2nd	3rd	4th	5th	6th	7th	8th	9th	10th	11th	12th
8.6	6.2	6.9	7.7	8.4	8.7	9.1	9.7	10.2	11.0	11.9	12.4

#### \*CRITERIA

Air Temperature, (in immediate vicinity of cooler) 32°C

Inlet water temperature, (immediately prior to cooler inlet) 27°C.

All capacities and performance data is based on the assumption that adequate ventilation has been supplied to the unit as per the installation instructions.

Ratings are based on intermittent use under environmental conditions of ARI Standard 1010 (self contained, mechanically refrigerated drinking water coolers) and UL399 (drinking water coolers).

### WEIGHTS AND DIMENSIONS

IC8	WEIGHT	WIDTH	DEPTH	HEIGHT	SHIPPING VOLUME
NETT	12.5kg	210mm	410mm	290mm	
PACKED	13.5kg	230mm	460mm	330mm	0.035M <sup>3</sup>

### WARRANTY

The Waterworks IC8 water coolers are covered by a 2 Year Comprehensive Warranty (copy available on request). The warranty provides comprehensive parts and labour coverage, for the period of 2 years from the date of original sale.



Waterworks Australia Pty Ltd ABN 51 064 901 239  
 48 Neumann Road Capalaba Queensland 4157  
 Phone (07) 3390 3777 • Fax (07) 3390 1766  
 Email sales@water-works.com.au • www.water-works.com.au



# RM 30 BLIZZARD

AWARD WINNING DESIGN, PROVEN PERFORMANCE



- Designed in Australia by Waterworks®
- 100% Rust Proof Cabinet
- Optional Filtration
- Optional Glass Filler
- UV Stabilised Cabinet
- 1 Year Comprehensive Warranty
- Impact Resistant Construction
- Pressure Reducing Valve and Shock Arrestor - protect from water mains pressure surges
- High Cooling Capacity
- Modern Granite Look Finish

*Design Registration  
No. 158110.  
Unit depicted has  
optional Glass Filler fitted.*



*Building and  
Construction Sites*



*Offices and  
Corporate Buildings*



*Standard Unit  
(bubbler only)*

# RM 30 BLIZZARD

AWARD WINNING DESIGN, PROVEN PERFORMANCE

## GENERAL FEATURES

**RUST PROOF CABINET:** The RM 30 Blizzard water cooler cabinets are made of rota-moulded, pigmented polyethylene. This U.V. stabilised material provides an external cabinet which is durable, modern and 100% rust proof.

Chilling tank - 1.9L stainless steel chilling tank.

IP rating 2-3.

**SERVICE ACCESS:** The front access panel is secured with four (4) concealed screws. Removal of this panel provides access for any purpose including service, maintenance and filter replacement.

**VANDAL RESISTANCE:** The top and basin on the RM 30 Blizzard is a single piece, (not numerous parts screwed together). This, combined with the internally fitted drain grill and the robust nature of polyethylene, provides unequalled vandal resistance.

## OPTIONAL FEATURES:

**FILTRATION:** An internal or external Waterworks filter will reduce sediment, chemicals, organic compounds and impurities which can adversely affect the quality and taste of your drinking water. Periodic filter replacement is easily achieved through the front panel. \*NB Always specify "F" option in model number.

**TWO WAY GLASS FILLER:** When fitted to the standard, (bubbler only) unit, the 2 way glass filler allows one touch activation for precise pouring or hands free for continuous flow. \*NB Always specify "GF" option in model number.

## INSTALLATION CONNECTIONS

**ELECTRICAL:** A 1.5 metre cordset with standard 3 pin plug is provided. The RM 30 Blizzard of water cooler does not have any specialised power requirements and can be plugged into any standard 240V 1PH 50Hz power point. Power consumption Ambient Temp 25deg. (kw.h/24h) 0.044.

**WATER INLET:** The inlet is an industry standard 1/2" female BSP threaded connection situated on the rear of the cooler, (see installation instructions for exact rough in details).

**DRAIN OUTLET:** The drain outlet and integrated 'P' trap provide an industry standard 40mm connection situated on the rear of the cooler. (see installation instructions for exact rough in details).

## WARRANTY

**1 YEAR COMPREHENSIVE WHOLESALE WARRANTY:** The entire range of Waterworks RM Series water coolers is covered by a 1 Year Comprehensive Warranty (copy available on request). The warranty provides comprehensive parts and labour coverage, for the period of 1 year from the date of original sale.

## SHIPPING DETAILS

PACKED WEIGHT: 28kg

PACKED VOLUME: 0.208M<sup>3</sup>

PACKED DIMENSIONS: 420mmW x 420mmD x 1180mmH

## CAPACITIES CHART

MODEL NUMBER	AMBIENT TEMP	INLET TEMP	LITRES/HR 10°C WATER	RESERVOIR VOLUME
RM30	32°C	27°C	28.3 LPH	1.9 Litre

\* Based on intermittent use under environmental conditions of ARI Standard 1010 and installation requirements of ARI Standard 1020.

\*\* Due to our policy of continuous development, specifications are subject to change without notice.

\*\*\*Colours are as close to actual as printing processes allow.

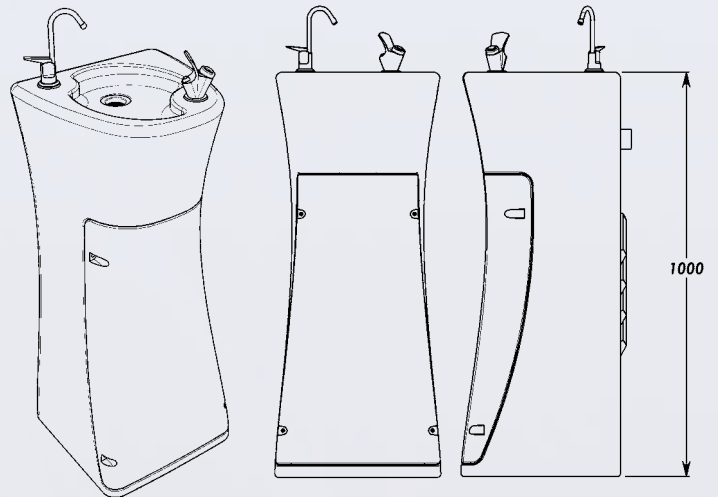
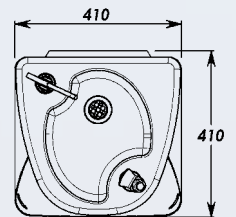

Distributed by...



Waterworks Australia Pty Ltd ABN 51 064 901 239  
48 Neumann Road Capalaba Queensland 4157  
Phone (07) 3390 3777 • Fax (07) 3390 1766  
Email sales@water-works.com.au • www.water-works.com.au



# IC1000

REMOTE COOLING & STORAGE SYSTEMS



- 60 Litre Storage
- Stainless Steel Reservoir
- Cools 120 Litres per Hour
- Services up to 6 outlets
- Heavy Duty construction
- Designed and built in Australia
- Superior Insulation and Energy Efficiency
- 2 Year Comprehensive Wholesale Warranty
- Exclusive Refrigeration Management System and Alarm
- Ideal for Schools, Mines, Sports Facilities, Dining Halls and any other High Demand applications



Mines and other Heavy Industrial Applications



Supplies from one to six Remote Faucets



Ideal for Schools and Sporting Facilities

# IC1000

## REMOTE COOLING & STORAGE SYSTEMS

### GENERAL INFORMATION

Our Waterworks IC1000 water cooling and storage system provides enough cold water to cope with the most extreme periods of high demand. The combination of extreme cooling performance and a significant volume of stored cold water, make these coolers ideal for many applications such as Public access areas, Schools, Mines, Construction sites and Sporting Venues.

The IC1000 is a remote cooling system, which means it can be installed in-line, just prior to whatever tap-ware is most appropriate for the individual application. Whether that be a single faucet for high volume draw-off or a trough of up to 6 bubbler faucets at a school or sporting club. (See picture for example)

### COOLING SYSTEM

The cooling system of the Waterworks IC1000 utilises industry leading technology. The hermetically sealed, dynamic condensing unit features superior insulation which prevents heat gain and therefore increases energy efficiency, while the Refrigeration Management System and alarm prevent the system from overheating due to either extreme ambient conditions or lack of clear airflow over the condenser coils. The sealed unit contains 330 grams of ozone friendly R134a refrigerant.

### WARRANTY

The IC1000 is covered by the Waterworks Wholesale Warranty, (copy available on request). This provides 2 years of comprehensive coverage, including parts and labour.

### INSTALLATION

The universal design of the IC1000 water coolers allows for easy installation. They are often installed in-line to provide cooled water to a bank of bubbler troughs, (such as in the image below), but can be used in many varied applications. A 1.2 metre cord set with 3 pin plug is included and this can be connected to any Australian Standard 240V 50Hz single phase power outlet, while both of the plumbing connections, (inlet and outlet) are 1/2" (male) BSP threaded connections. When installing the IC1000, place it upright, in an area protected from the elements, on a flat, stable surface and be sure to provide adequate ventilation space and access to the service panel.

MODEL:	IC1000
DESCRIPTION	REMOTE CHILLER
RESERVOIR VOLUME	60 LITRES
LITRES / HOUR	120 LPH
OUTLETS	UP TO 6
CABINET WIDTH	804mm
CABINET DEPTH	644mm
CABINET HEIGHT	806mm

*Typical installation of Remote IC000 with bubbler trough, (not furnished with cooler)*

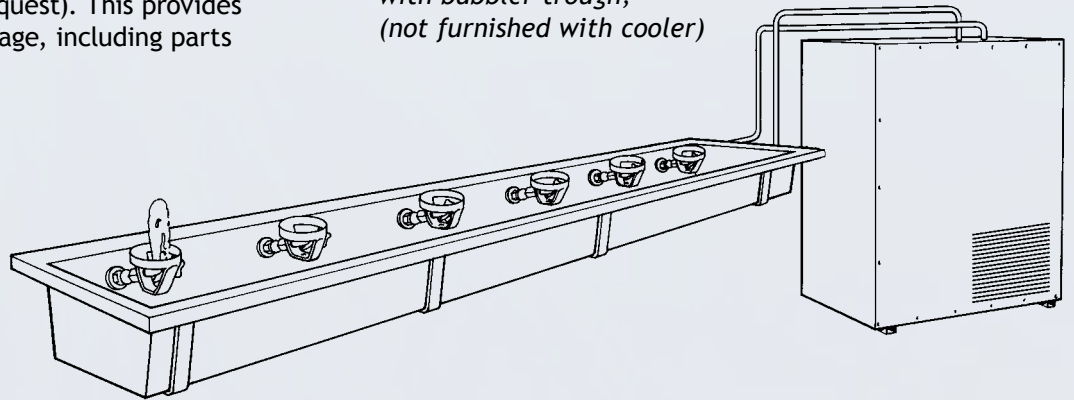

As part of Waterworks Australia's policy of continuous improvement, we reserve the right to alter specifications at anytime without notice.

*Distributed by...*



Waterworks Australia Pty Ltd ABN 51 064 901 239  
48 Neumann Road Capalaba Queensland 4157  
Phone (07) 3390 3777 • Fax (07) 3390 1766  
Email sales@water-works.com.au • www.water-works.com.au



# SWING & TWIST FILTRATION SYSTEMS

*Ideal for Water dispensers, Refrigerators,  
Dishwashers, Coffee makers, Ice makers  
or under-sink filtration.*

*Advanced, innovative, and oh so simple!*



- Automatic shut off filter head makes filter replacements safe and easy
- Compact design allows maximum use of space under sinks or behind water dispensers
- Cost saving - Reduces servicing costs by saving time on filter changes
- Easy cartridge replacement - No housing spanners or tools required
- O'ring is on the filter - New O'rings with every filter change
- Single, twin or triple filtration systems available.



# SWING & TWIST FILTRATION SYSTEMS

## FILTER CARTRIDGE OPTIONS

SEDIMENT CARTRIDGE	HOLLOW-FIBER
Polypropylene pre filter for the removal of dirt sediment, rust and particles.	Superior micro-fine membrane for the removal of bacteria.
Flow rate 2L per minute	Flow rate 2L per minute
Filter replacement - 3650L or 6 months. Which ever occurs first.	Filter replacement - 3000L or 6 months. Which ever occurs first.
5 micron	0.3
Minimum operating temp: 4-40C	Minimum operating temp: 4-40C

CARBON BLOCK	ULTRA CARBON BLOCK
Silver impregnated carbon block for chemical, taste and odour removal.	Silver impregnated carbon block for chemical, taste and odour removal.
Flow rate 2L per minute	Flow rate 2L per minute
Filter replacement - 3650L or 6 months. Which ever occurs first.	Filter replacement - 3650L or 6 months. Which ever occurs first.
5 micron	1 Micron
Minimum operating temp: 4-40C	Minimum operating temp: 4-40C

## DIMENSIONS CENTIMETRES

	HEIGHT	WIDTH	DEPTH
Single	31	8	9
Twin	31	15.5	9
Triple	31	24	9



*Distributed by...*

## NOTES

Filter should be pre flushed prior to attaching to equipment or after long periods of inactivity.

Do not use with water that is microbiologically unsafe or of unknown quality.

Turn water off to filter system if not in use for extended periods.

Automatic shut off valve automatically shuts off water supply to the system when filter is removed.

Filter life can vary depending on water quality and demand.

A 350Kpa pressure limiting valve **MUST** be installed.

Installation of your water filter system must only be carried out by a licensed technician and all aspects of the installation must comply with current local authority standards and regulations.



Waterworks Australia Pty Ltd ABN 51 064 901 239  
 48 Neumann Road Capalaba Queensland 4157  
 Phone (07) 3390 3777 • Fax (07) 3390 1766  
 Email sales@water-works.com.au • www.water-works.com.au



# AQUANET PREMIUM RANGE

MAINS PRESSURE QUICK CONNECT FILTERS  
*For Premium Water Quality Choose Aquanet®*



- Twin under-sink option available (Faucet available)
- Connects to any Point of Use or Mains Pressure cooler
- May be installed as single systems or in combination systems
- Available in 7, 10, 12 & 17" combinations
- Fluoride reduction available
- High flow filter available for coffee machine or direct connect installations
- Filter protection Silver Zeolite by Agion®
- Scale control by polyphosphate
- Exclusive quick change cartridge
- 3/8th - 3/8th or 3/8th - 1/4" inlet/outlet connections available

# AQUANET PREMIUM RANGE

## MAINS PRESSURE QUICK CONNECT FILTERS

For Premium Water Quality Choose Aquanet®

FEATURES								
MODEL	F-A-17-CHF-0.5	F-A-12-CB+-0.5	F-A-10-CBP-1	F-A-10-SED-5	F-A-10-CB+-1	F-A-07-CB+-0.5	F-A-07-BLANK	F-A-12-FLO-000
Flow rate (lpm)	6.0 lpm	3.0 lpm	3.0 lpm	3.0 lpm	3.0 lpm	3.0 lpm	4.0 lpm	3.0 lpm
Capacity certified rated litres	2000	4000	4000	4000	4000	2000	n/a	2000
Absolute Micron filtration	0.5µ	0.5µ	1µ	5.0µ	1µ	0.5µ	n/a	n/a
Single cartridge design	✓	✓	✓	✓	✓	✓	✓	✓
Sanitary & quick change cartridge	✓	✓	✓	✓	✓	✓	✓	✓
Exclusive head & cartridge patent pending	✓	✓	✓	✓	✓	✓	✓	✓
Protects appliances from lime scale build-up	✓	✓	✓	✓	X	X	X	X
Exclusive high flow performance carbon block	✓	✓	X	X	X	X	X	X
Built-in 5 micron pre-filtration system	✓	✓	X	X	X	X	X	X
AGION EPA registered anti-microbial technology	✓	✓	X	X	X	X	X	X
Multi-Tap® design to allow connection directly to cold water existing sink faucet *	✓	✓*	X	X	X	X	X	X
Performance certified under ANSI/NSF Std 42 & 53	✓	✓	X	X	X	X	X	X
PERFORMANCE								
Turbidity, dirt and rust	✓	✓	✓	✓	✓	✓	n/a	n/a
Off tastes and odors	✓	✓	✓	X	✓	✓	n/a	n/a
Chlorine	✓	✓	✓	X	✓	✓	n/a	n/a
Molds and algae	✓	✓	✓	X	✓	✓	n/a	n/a
Oxidized iron	✓	✓	✓	✓	✓	✓	n/a	n/a
Oxidized manganese	✓	✓	✓	✓	✓	✓	n/a	n/a
Oxidized sulfides	✓	✓	✓	✓	✓	✓	n/a	n/a
Giardia labia cysts	✓	✓	✓	X	✓	✓	n/a	n/a
Cryptosporidium parvum cysts	✓	✓	✓	X	✓	✓	n/a	n/a
99% of all particles, 1.0 micron and larger	✓	✓	✓	X	✓	✓	n/a	n/a
99% of all particles, .5 micron and larger	✓	✓	X	X	X	✓	n/a	n/a
99% of all particles, 5.0 micron and larger	✓	✓	✓	✓	✓	✓	n/a	n/a
Scale control	✓	✓	✓	X	X	X	n/a	n/a
Anti-microbial protection	✓	✓	X	X	X	X	n/a	n/a
Selective organic chemicals (see data sheet) **	✓	✓	✓	X	✓	X	n/a	n/a
Methyl tertiary-butyl ether (MTBE)	✓	X	X	X	X	X	n/a	n/a
Lead	✓	✓	X	X	X	X	n/a	n/a
Chloramines	✓	X	X	X	X	X	n/a	n/a
Trihalomethanes (TTHM's)	✓	X	X	X	X	X	n/a	n/a
Volatile organic chemicals (VOC 's)	✓	X	X	X	X	X	n/a	n/a
Fluoride Reduction	X	X	X	X	X	X	n/a	✓

\*\* varies by model, see performance data sheet for details

As part of Waterworks Australia's policy of continuous improvement, we reserve the right to alter specifications at anytime without notice.

Distributed by...



Waterworks Australia Pty Ltd ABN 51 064 901 239  
 48 Neumann Road Capalaba Queensland 4157  
 Phone (07) 3390 3777 • Fax (07) 3390 1766  
 Email sales@water-works.com.au • www.water-works.com.au

### CERTIFICATION

Aquanet® models F-A-12-CB+0.5 and F-A-17-CHF-0.5 are Tested and Certified by WQA International against NSF/ANSI Standards 42 and 53 for the reduction of:

### STD. NO. 42 - AESTHETIC EFFECTS

- Chemical Reduction
- Taste and odor
- Chlorine Taste and odor
- Chloramines Taste and odour
- Mechanical Filtration
- Particulate Class 1

### STD NO. 53 - HEALTH EFFECTS

- Chemical Reduction
- Lead
- MTBE
- TTHM's
- VOC's
- Mechanical Filtration
- Turbidity
- Cyst

### HOUSING INTEGRITY

- Double O'ring on filter - Not in the head (Eliminates need to replace O'rings)
- All housings are leak tested at point of manufacture.
- Burst tests are carried out in batches for every production.



STOP destructive water damage from disastrous plumbing failures with

# SAFEGUARD™

## WATER LEAK DETECTOR & AUTOMATIC SHUT OFF VALVE

### FEATURES & BENEFITS

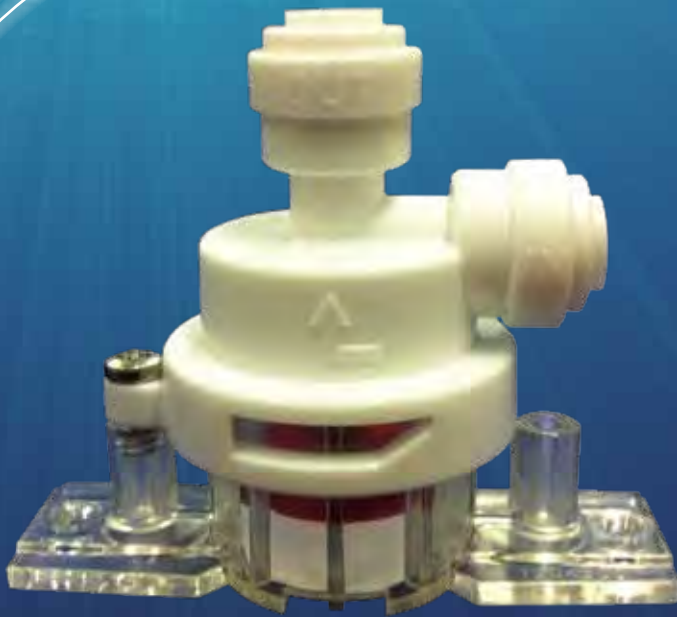

- Works on Hydraulic & mechanical principles
- Requires no power supply
- No batteries needed
- Requires no electronic sensors
- Automatic shut off
- Sensor pad easily replaced
- Transparent inspection cylinder
- Left or right hand inlet connections
- Vertical discharge outlet
- Quick connect fittings
- Proven reliability
- Complies to Aust/NZ operating pressures

**Safeguard™ is reusable, easily installed and economical.**

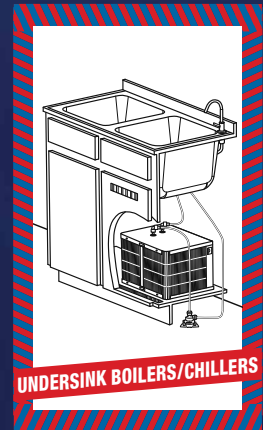
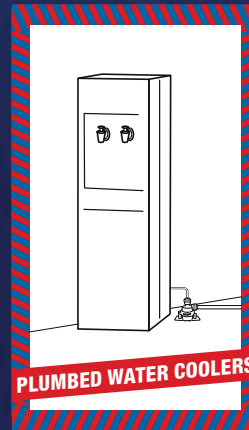
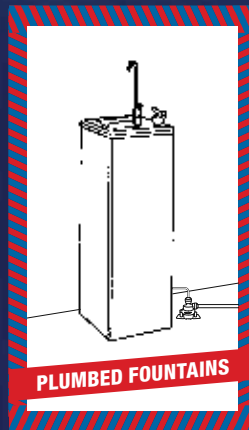
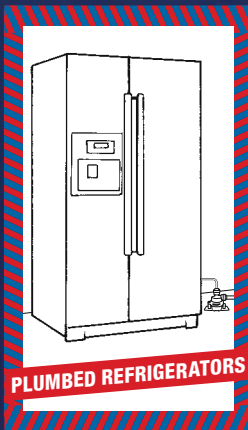
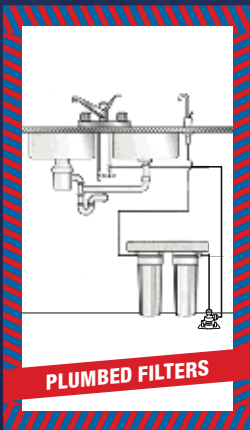

**Waterworks Safeguard prevents catastrophic indoor water damage without draining your budget. It automatically detects water leaks and instantly shuts off the water supply to the leaking appliance.**

# SAFEGUARD™

## WATER LEAK DETECTOR

### GENERAL FEATURES

Safeguard™ provides an economical means of protection for the home, office and business from water damage caused by leaks from faulty plumbing systems or appliances. It is attached "upstream" and below the connected appliance.

### FACT

One small leak or burst in a 1/4" water pipe can result in a flood of over 4000 litres over a 24 hour period.

### FUNCTION

Waterworks Safeguard™ works like a fuse on the incoming water line. Just as an electrical circuit breaker cuts off the electricity supply, Safeguard™ will shut down the water flow to the leaking filter, ice maker, water cooler, etc.

### APPLICATION

Safeguard™ offers technology that halts the water supply to failed plumbing installations on:

- Under-sink and remote water chillers
- Under-sink water filters
- POU in-line water coolers
- In-line water filters
- Water bubblers and fountains
- Reverse osmosis systems
- Undersink water boilers
- Water softeners
- Refrigerators and ice makers
- Tap-ware and glass fillers
- Coffee makers
- Many other appliances

#### Operation

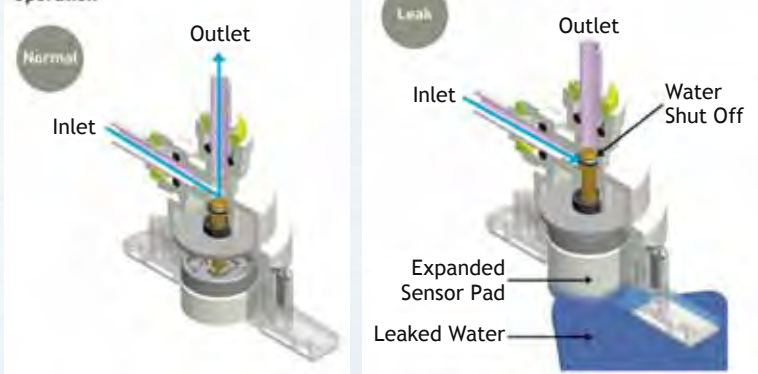

### OPERATION

Waterworks Safeguard™ is a remarkably innovative device; the compressed sensor pad simply reacts to minimal water contact at its base and rapidly expands to fill the cylinder which houses the spring loaded shut-off valve. This hydraulic force lifts the riser and enables the shut-off valve to close the incoming water line and stop the flow. It is easily re-set by replacing the disposable sensor pad.

### MAIN BENEFITS

Safeguard™ is the non electrical leak detection and prevention valve that gives PEACE OF MIND to the plumbing industry and quality water specialists.

### SPECIFICATIONS

Inlet/outlet:	1/4" quick connect fittings
Operating pressure:	50-700 Kpa
Material:	ABS and POM
Fixtures:	Securing screws and self adhesive pads included
Measurements (mm)	65H X 40W X 70L

Replace sensor pad on activation or 6 monthly whichever comes first.

Replacement sensor pads available in packs of 10

### WARRANTY

12 month replacement warranty on replacement parts. (conditions apply)

*Distributed by...*



Waterworks Australia Pty Ltd ABN 51 064 901 239  
48 Neumann Road Capalaba Queensland 4157  
Phone (07) 3390 3777 • Fax (07) 3390 1766  
Email sales@water-works.com.au • www.water-works.com.au



# WATER COOLER ACCESSORIES



**Waterworks Offer a Huge Range  
of Bottled Water, Mains Pressure  
and Point Of Use Accessories.**

# WATER COOLER ACCESSORIES



Bench top and floor standing well stands.  
Timber or metal.



Ceramic wells and stands



Non-spill valves  
and caps to fit  
most 15 & 19L bottles.

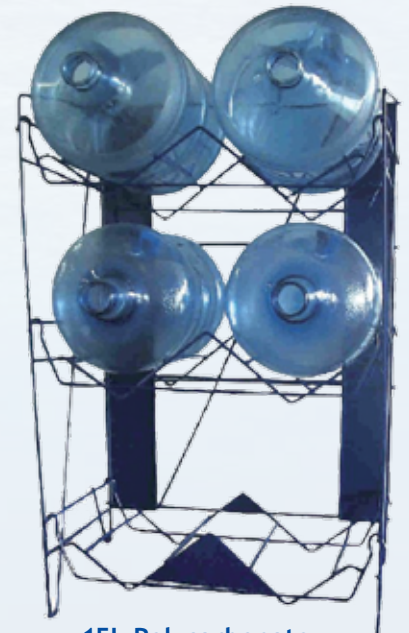

15L Polycarbonate  
bottle and bottle rack

POU conversion kits are  
available for all of our bottled water coolers.  
Easily converts bottled coolers into mains  
connected in-line systems.



Blok blok - Emergency  
water shut off devices



Fit Kit - Plumbing and  
installation fittings



Snap connect fittings



Cup dispensers

Water cooler  
& bottle cleaning  
brushes.



Manual & battery  
operated bottle pumps.  
Great for camping or  
working off site!



Aquanet  
drop in  
filter



Neoprene  
bottle covers  
15 & 19L



Distributed by...

Sims Refrigeration SA & NT  
188 Main Rd  
Blackwood, SA, 5051  
Phone: (08) 8370 3111  
Fax : (08) 8278 8318  
www.simsrefrig.com.au

As part of Waterworks Australia's policy of continuous improvement,  
we reserve the right to alter specifications at anytime without notice.



Waterworks Australia Pty Ltd ABN 51 064 901 239  
48 Neumann Road Capalaba Queensland 4157  
Phone (07) 3390 3777 • Fax (07) 3390 1766  
Email sales@water-works.com.au • www.water-works.com.au